

- NOTES:
1. 5/8" ϕ MOUNTING HARDWARE IS RECOMMENDED.
 2. MOUNTS THE BUTTERFLY MX 12 INCH SURFACE MOUNT UNIT.

UNLESS OTHERWISE SPECIFIED:
 DIMENSIONS ARE IN INCHES
 TOLERANCES:
 FRACTIONAL $\pm 1/32$
 ANGULAR: $\pm 2^\circ$
 TWO PLACE DECIMAL ± 0.010
 THREE PLACE DECIMAL ± 0.005
 INTERPRET GEOMETRIC
 TOLERANCING PER:
 ASME Y14.5 -2009

	NAME	DATE
DRAWN		
CHECKED		

TITLE: INSTALLATION		
SIZE A	PART NO. 33PED-BUT-004-304	REV 0
WEIGHT:	NO SCALE	SHEET 1 OF 6

ITEM NO.	PART NUMBER	DESCRIPTION	QTY.
1	33PED-BUT-004-304	3X3 304 SS TUBE	1
2	FACE PLATE 12S	12 INCH BMX FACE PLATE	1
3	BACK PLATE 12S	12 INCH BMX BACK PLATE	1
4	BASE PLATE 8 281	8" STANDARD BASE PLATE	1
5	COVER PLATE 8 3125	8" STANDARD COVER PLATE	1
6	KEYHOLE STUD	8MM KEYHOLE STUD	4

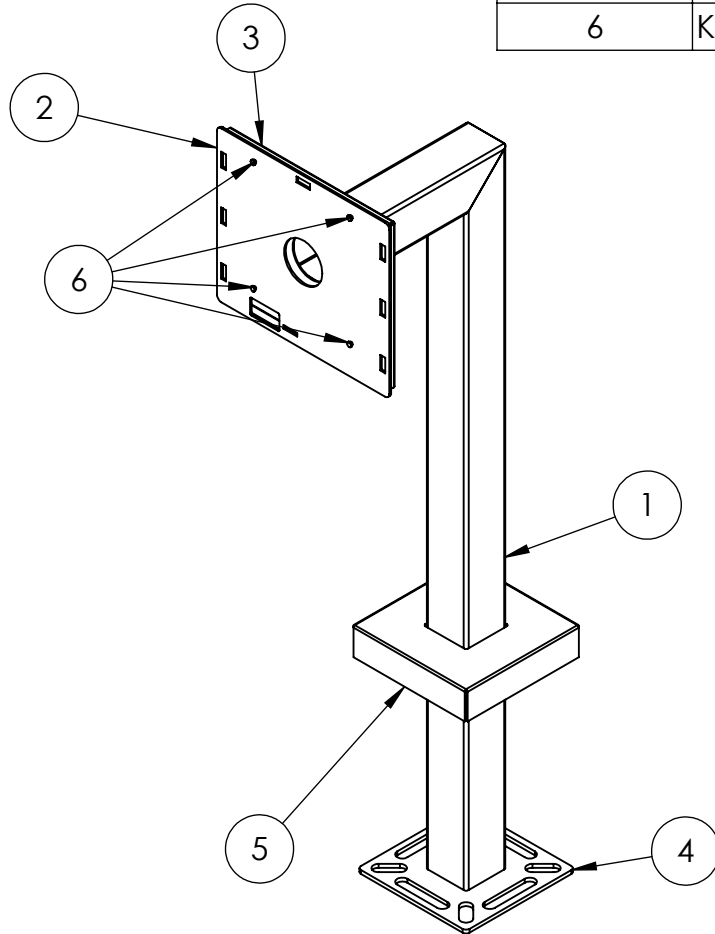

NOTES:

1. BUTT WELDED SECTIONS ARE NOT ALLOWED, EACH SECTION OF TUBE MUST BE FROM CONTINUOUS STOCK.
2. ALL WELDS ARE TO BE CONTINUOUS FILLET WELDS UNLESS NOTED OTHERWISE.
3. SEE STANDARD PREPARATION AND COATING INSTRUCTIONS FOR COATING PROCEDURE AND COLOR.
4. FASTENERS ARE TO BE BAGGED AND SHIPPED WITH PEDESTAL.
5. SEE STANDARD PACKAGING INSTRUCTIONS FOR PACKAGING PROCEDURE.

UNLESS OTHERWISE SPECIFIED:

DIMENSIONS ARE IN INCHES
TOLERANCES:
FRACTIONAL $\pm 1/32$
ANGULAR: $\pm 2^\circ$
TWO PLACE DECIMAL ± 0.010
THREE PLACE DECIMAL ± 0.005

INTERPRET GEOMETRIC
TOLERANCING PER:
ASME Y14.5 -2009

	NAME	DATE
DRAWN		
CHECKED		

TITLE:
ASSEMBLY

WEIGHT:	NO SCALE	SHEET 2 OF 6
SIZE	PART NO.	REV
A	33PED-BUT-004-304	0